

PLAN VIEW

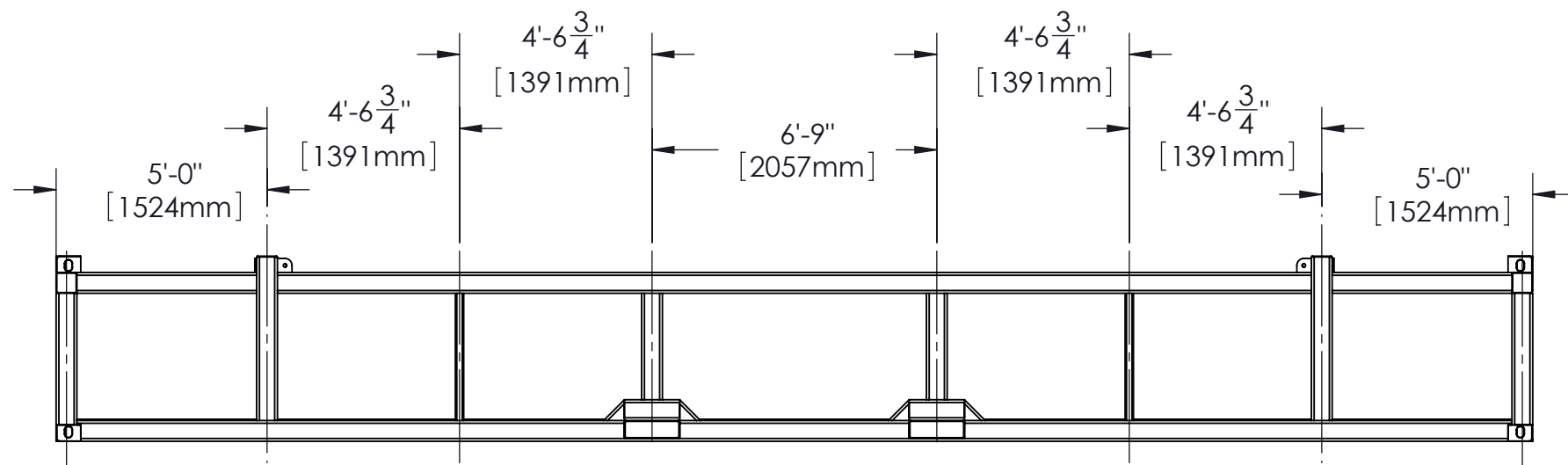

SIDE ELEVATION VIEW

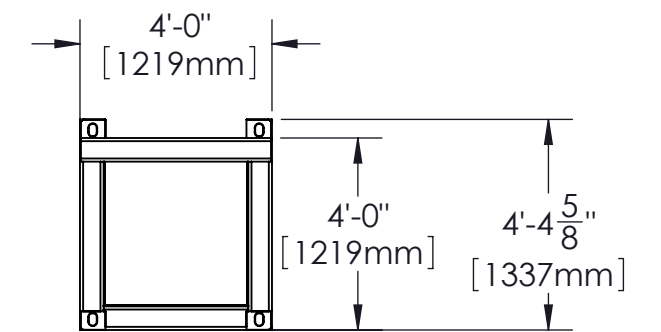

END ELEVATION VIEW

TARE WEIGHT: 10,187 LBS

REVISIONS			
REV.	BY	DESCRIPTION	DATE
A	JG	ISSUE FOR APPROVAL	11/16/2010

THIS DRAWING IS AN INSTRUMENT OF SERVICE AND SHALL REMAIN THE PROPERTY OF GAUTHIERS OIL FIELD RENTAL. THIS DRAWING SHALL NOT BE REPRODUCED, PUBLISHED, OR USED IN ANY OTHER MANNER WITHOUT THE EXPRESSED WRITTEN PERMISSION OF GAUTHIERS OIL FIELD RENTAL.

DRAWN BY: JG	DESCRIPTION: 4' x 35' x 4' DNV Basket Sketch
CHECKED BY: CD	
APPROVED BY: GG	REFERENCE DOCUMENT NUMBER: DOC NUMBER
DATE: 11/16/2010	DRAWING NUMBER: DOC NUMBER
SCALE: 1:64	



2784 NE EVANGELINE THRUWAY LAFAYETTE, LA 70507
PH 337.235.8548 TOLL FREE 877.235.8549

SHEET NUMBER: SHEET 1 OF 1	REVISION: A
-------------------------------	----------------